

INDUSTRIAL GASOLINE ENGINE

Kubota WG Series (4-Cylinder)

WG2503-G-E3



Rated Power

45.5 kW @ 2700 rpm

Performance Curves

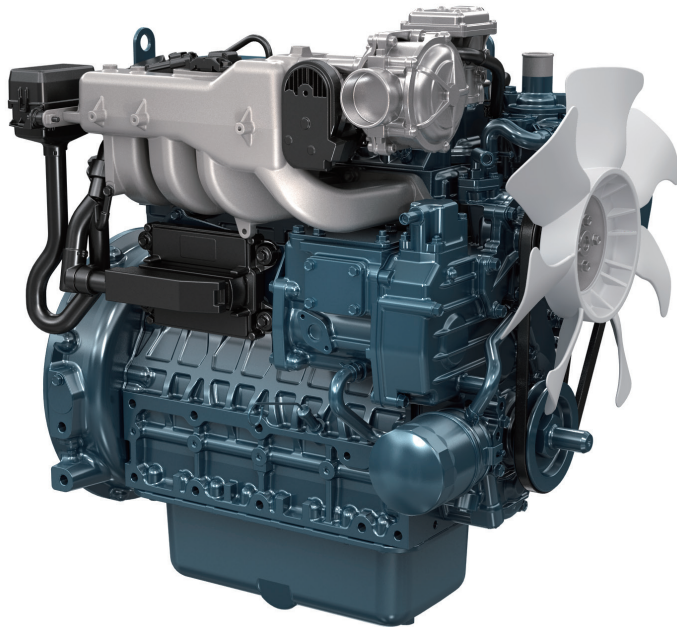

Photograph may show non-standard equipment.

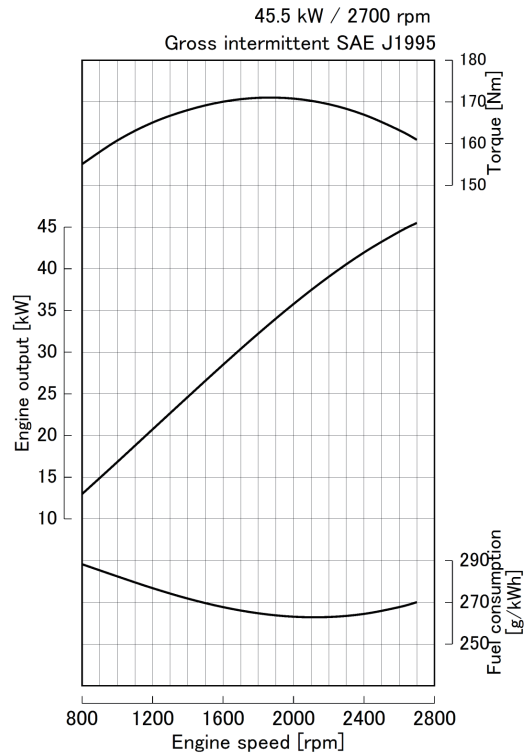

Features and Benefits

Emissions

Kubota's WG2503-G-E3 engine has been designed to comply with EPA Tier 2 / CARB Tier 3 and EU Stage V.

Fuel Flexibility

The installation compatibility that exists between Spark-Ignition engines (SI) and Compression-Ignition engines (CI) is convenient for customers who need fuel flexibility for their products. The Kubota WG2503 includes gasoline, LPG, and natural gas versions, as well as a dual fuel (gasoline and LPG) version.

Durability and Reliability

Kubota's WG2503 SI engines are designed after Kubota O3 Series diesel (CI) engines. While keeping the same footprint as the V2403 diesel, they offer performance similar to that of our turbo diesel engines, which are known worldwide as reliable industrial engines. The WG2503 engine offers very low vibration and extremely low noise.

WG2503-G-E3

Engine Specifications

Engine model		WG2503-G-E3
Emission regulation		EPA Tier 2/ CARB Tier 3 + EU Stage V
Type		Vertical, water cooled 4-cycle spark ignited engine
Fuel type		Gasoline
Cylinders		4
Bore and stroke	mm (in)	88.0 x 102.4 (3.46 x 4.031)
Displacement	L (cu.in)	2.491 (152.0)
Aspiration		Naturally aspirated
Aftertreatment		Three-way catalyst
Rated output / speed *1	kW (HP) / rpm	45.5 (61.0) / 2700
Maximum torque / speed *1	Nm (lb-ft) / rpm	171.0 (126.1) / 1800
Length x Width x Height *2	mm (in)	646 x 513 x 703 (25.4 x 20.2 x 27.7)
Dry weight *2	kg (lbs)	195 (430)

Specifications are subject to change without notice.
Dimensions and dry weight are according to Kubota's standard specification.
Dimensions and weight depend on completed specifications.
LPG: Commercial liquid propane gas only. Equivalent to propane HD-5 of GPA standard.
Natural gas: The performance shown is with Japanese standard natural gas.
The lower heating value: 9699 kcal/m³ (1090 BTU / ft³)

*1: SAE J1995 gross intermittent

*2: Exclude cooling fan and exclude aftertreatment unit

Dimensions

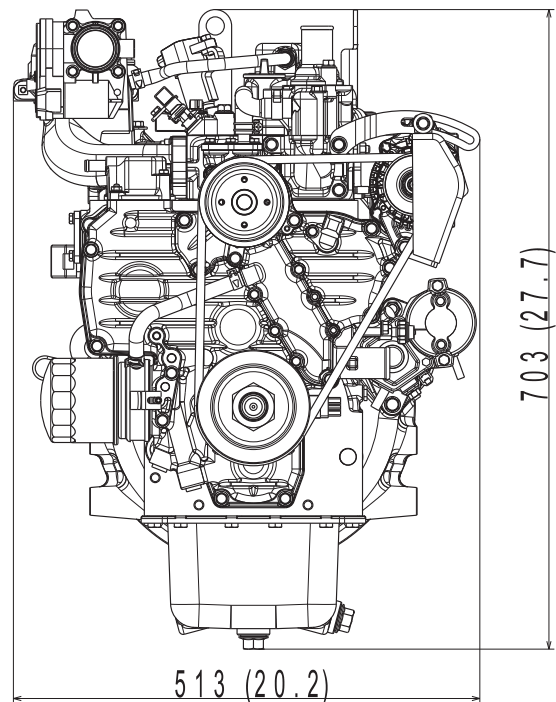
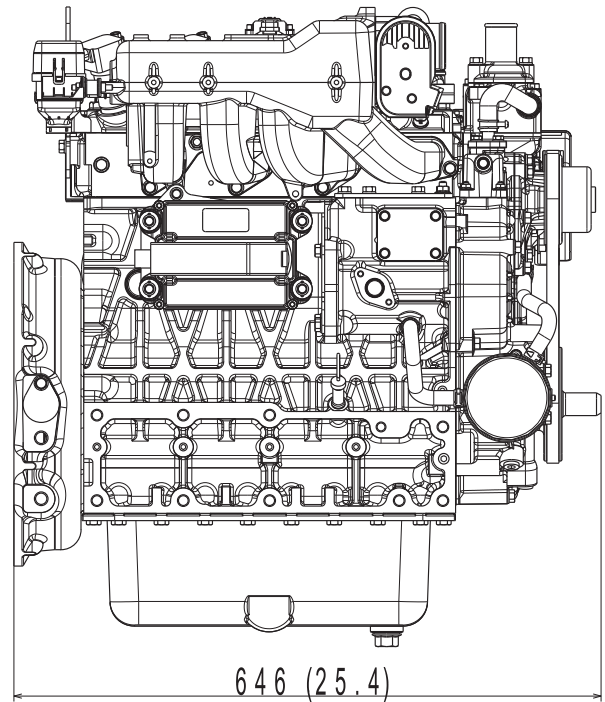

Kubota Corporation

2-47, Shikitsuhigashi 1-chome Naniwa-ku, Osaka, 556-8601 Japan

<https://engine.kubota.com/en/>

ASP-WG2503-G-E32601-R3-8-238142